

PARÇA KODU PART CODE	PARÇA ADI PART NAME	ERKEK TERMINAL MALE TERMINAL	a ÖLÇÜSÜ (AYAR) a MEASURE (SET)	s ÖLÇÜSÜ (KALINLIK) s MEASURE (THICKNESS)	Malzeme Material	Kaplama / Coating		
						SN	AG	Nİ
MS 2121.80 RP	KİLİTLİ DİŞİ FİŞ ZİMBALI 6.3 (0.80) =RP=	0.80	0.55±0.1	0.35±0.05	(CuZn30) Pirinç / Brass	-	-	-
MS 2121.80 RPK	KİLİTLİ DİŞİ FİŞ ZİMBALI 6.3 (0.80) =RPK=	0.80	0.55±0.1	0.35±0.05	(CuZn30) Pirinç / Brass	+	-	-
TD 2121.50 RP	KİLİTLİ DİŞİ FİŞ ZİMBALI 6.3 (0.50) =RP=	0.50	0.35±0.1	0.38±0.05	(CuZn30) Pirinç / Brass	-	-	-
TD 2121.80 DP	KİLİTLİ DİŞİ FİŞ ZİMBALI 6.3 (0.80) =DP=	0.80	0.55±0.1	0.38±0.05	(CuZn30) Pirinç / Brass	-	-	-
TD 2121.80 RP	KİLİTLİ DİŞİ FİŞ ZİMBALI 6.3 (0.80) =RP=	0.80	0.55±0.1	0.38±0.05	(CuZn30) Pirinç / Brass	-	-	-
TD 2121.80 RPK	KİLİTLİ DİŞİ FİŞ ZİMBALI 6.3 (0.80) =RPK=	0.80	0.55±0.1	0.38±0.05	(CuZn30) Pirinç / Brass	+	-	-
TD 2121.80 RÇN	KİLİTLİ DİŞİ FİŞ ZİMBALI PASLANMAZ 6.3 (0.80) =RÇN=	0.80	0.55±0.1	0.40±0.05	Nikel kaplı çelik / Nickel plated Steel	-	-	+

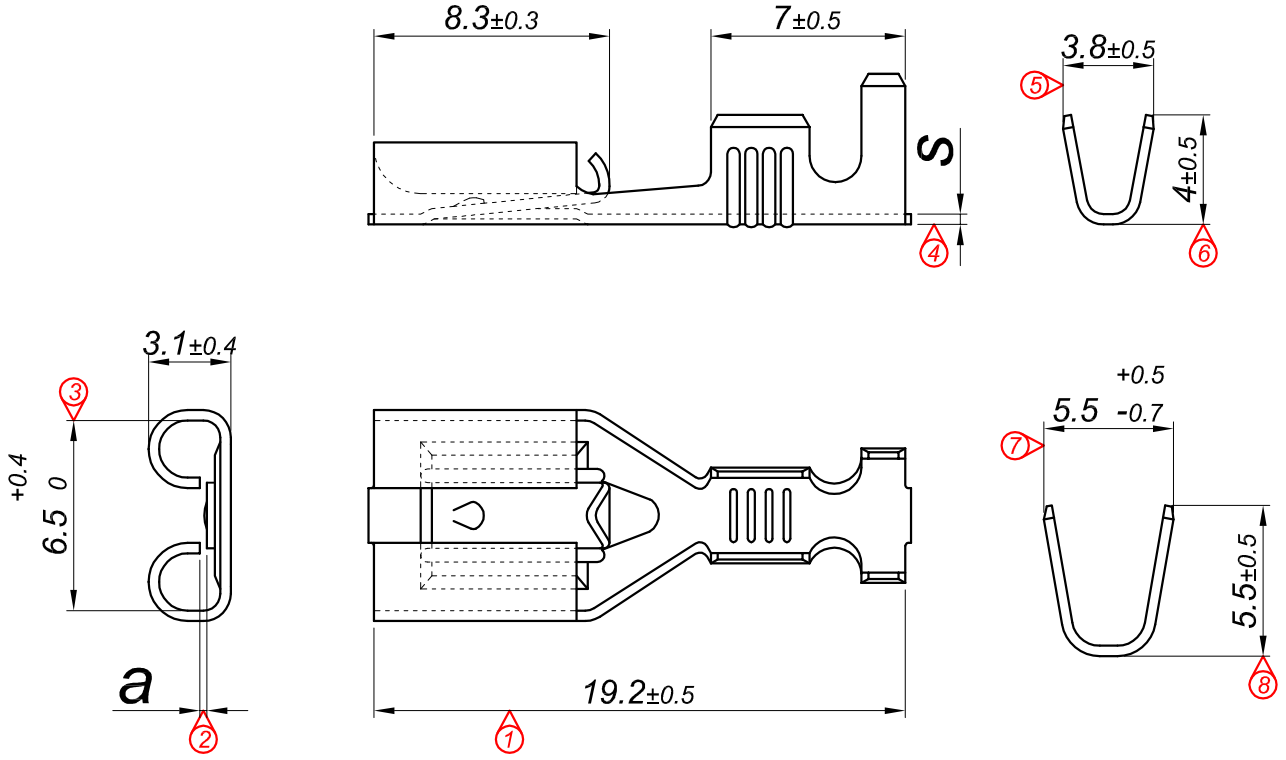

Perspektif
Perspective

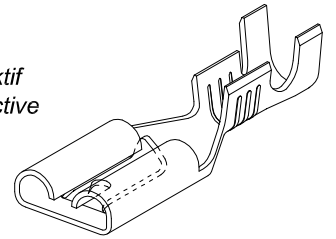

Kalıp çıkış yönü
Mold output direction ← → Makara açılım yönü
Reel opening direction

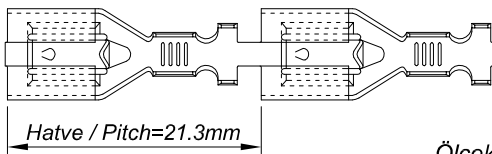

Hatve / Pitch=21.3mm

Ölçek
Scale : 2 / 1

Kablo Kesiti

Wire Section : 0.75 - 2.50 mm²

Resim üzerinden ölçü almayınız
do not measure on drawing

Tarih / Date	24.08.2011	İmza / Signature	Ölçek / Scale		
Çizen / Desing	M.Yağcı		5 / 1	01	5.5±0.5 Ölçüsü 5.5 +0.5 / -0.7 Olarak Değişt.
Onay / Approval	S.Gölcük			No	Değişiklik / Revision
					Tarih/Date



Parça Adı:
Part Name

KİLİTLİ DİŞİ FİŞ ZİMBALI 6.3

Parça Kodu:
Part Code

TD 2121